

Quality Solution For All Growers . . . . .



# Wash Spray Unit

From ***KW Automation***



Photographed with optional Gravity Feed Hopper.



## Multi Adjustable Highly Versatile

- ▶ **Numerous** brush total & brush width combinations to meet Grower needs.
- ▶ **Dual** purpose design. Washes & Sprays.
- ▶ **Unique** chain driven brushes for quieter operation.
- ▶ **Height Adjustable** legs for smooth flow of fruit line.
- ▶ **Durable** powdercoated for extra protection.
- ▶ **Gentle** handling for your fruit.
- ▶ **Safe** and clean with easily accessed hinged lid.

Being able to wash & spray your fruit without excessive handling, aids in the gentle handling of your fruit, at the same time increasing productivity.

The **Wash Spray Unit** is totally enclosed with an easily accessed divided collecting tray with outlets fitted for both washing and spraying operations.

One wash nozzle and soft nylon roller brushes gently wash the fruit. Flicker bars agitate the

rollers to shake off excess water.

The fruit then proceeds through into the spray section. One spray nozzle sprays the fruit while the soft brush rollers aid in the total coverage.

In conjunction with other optional extras from KW Automation( listed over the page ) the **Wash Spray Unit** gives a most formidable performance.

### Manufactured By:



***KW Automation***

PO Box 121, Old Bowling Green Rd  
Palmwoods, Queensland 4555 Australia

Int (61) - (07) 5445 9549 - Fax (07) 5445 0499  
Web Site: [www.kwautomation.com.au](http://www.kwautomation.com.au)

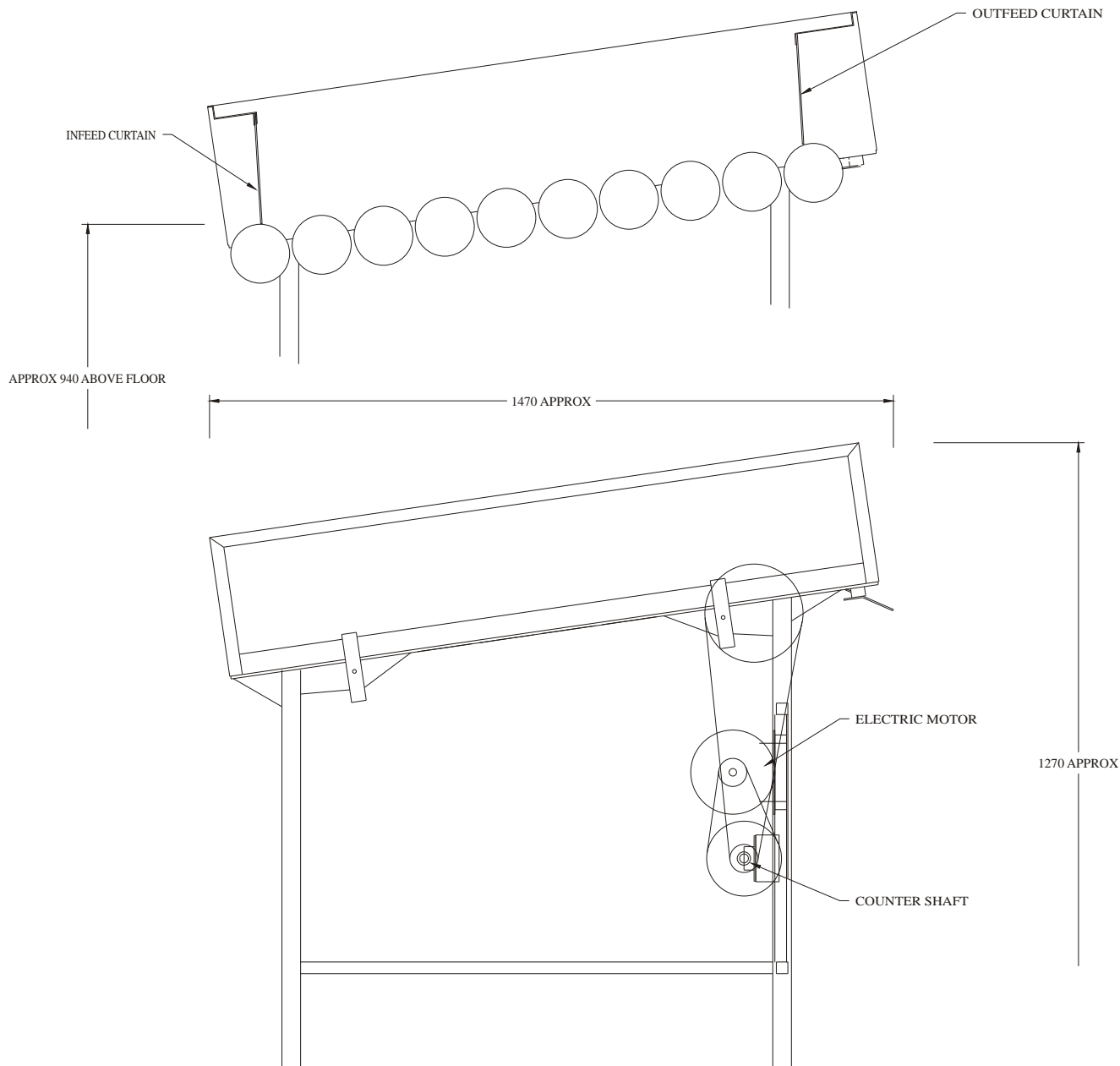

Wash Spray Unit	Specifications
Capacity of Motor	0.18 kW (1/4 HP) - 460mm Brush
Power Supply Req'd	240V or 415V
Length of 10 Brush Unit	1.470 Metres
Width of 10 Brush Unit	.750 Metres (460mm Wide Brush)
Height of 10 Brush Unit	1.270 Metres
No. of Brushes per Unit	10,12,14,16 or 20
Width of Brushes	460mm,600mm or 900mm
Std Brush Speed	116 R.P.M.
Optional Brush Speed	76 R.P.M.

**N.B.**

- Optional : - 100 Ltr Fibreglass Spray Storage Tank and Pump System to supply spray nozzles.
- Optional : - Centrifugal Pump for wash application.
- Optional : - Horse Hair Brushes.
- Optional : - Gravity Feed Hopper.

Please note all plans & specifications may change without further notice.